

LAMPIRAN 1

Proses Penyandaran Secara *Ship to ship*

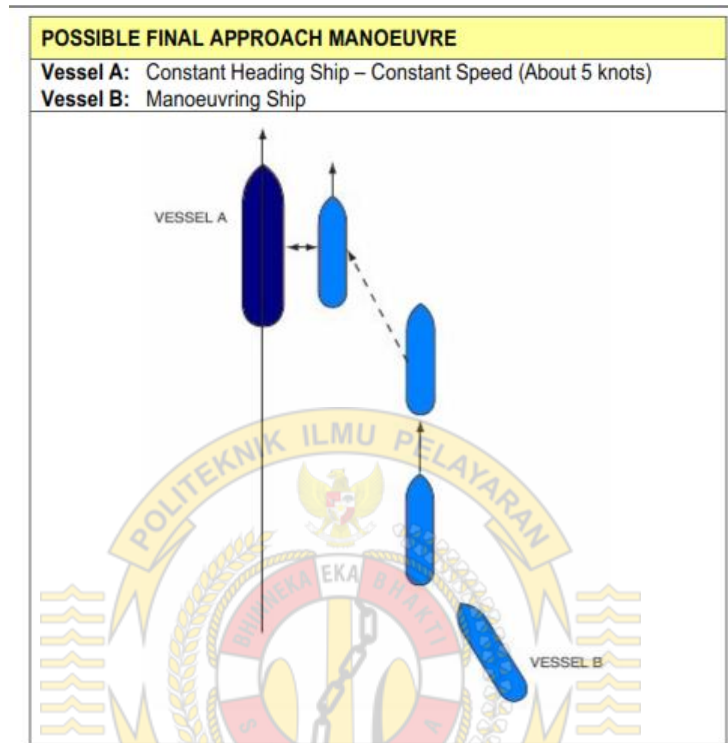

Olah Gerak Kapal *Ship to Ship Transfer*

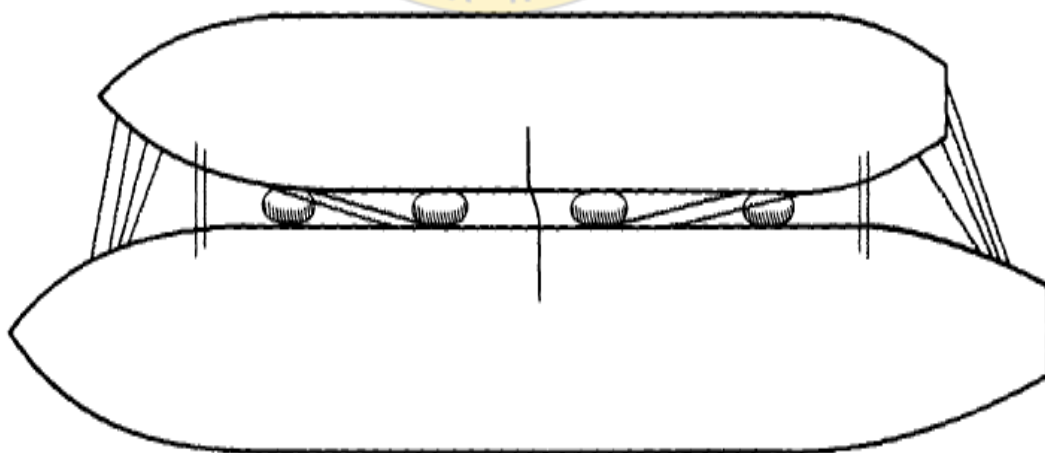

Ship to Ship Mooring Arrangement

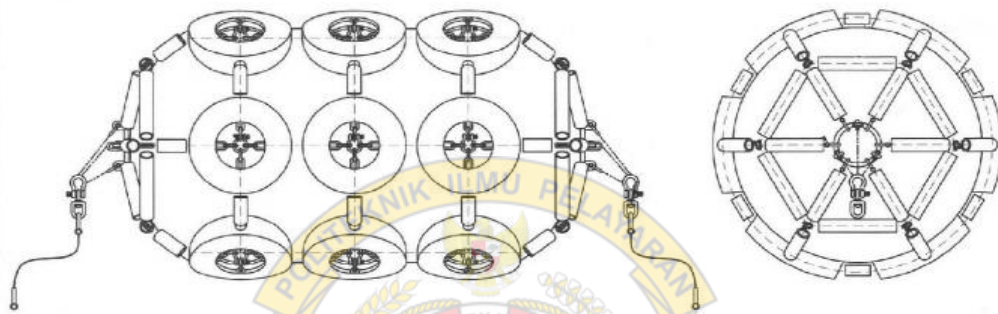
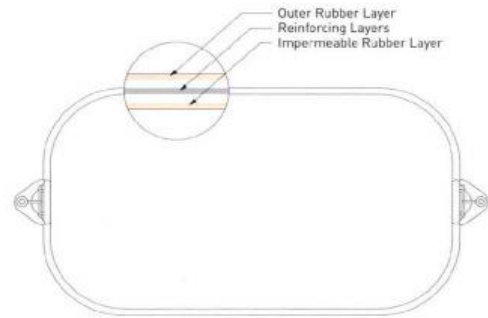

Fender yang Digunakan untuk Ship to Ship

NOTE: MANIFOLD LOCATIONS SHOULD BE CLEARLY MARKED - DAY OR NIGHT.

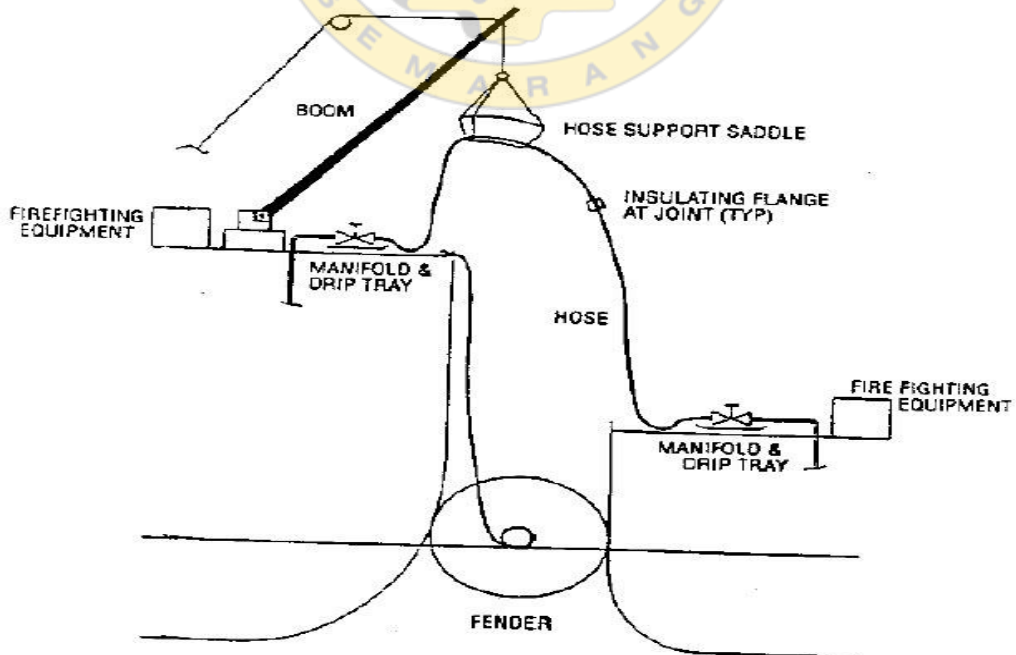

Ship to Ship Transfer Arrangement



Kondisi Kapal Setelah Penyandara Selesai



Kondisi Kapal Saat Kegiatan Bongkar Muat