

SUC. FLANGE
JIS 5K-250A

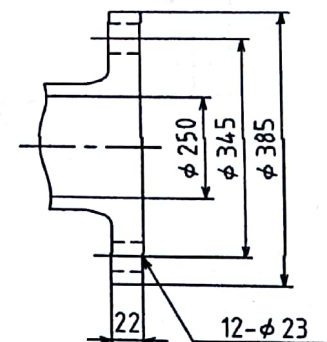

DIS. FLANGE
JIS 5K-250A

NOTICE

1. Terminal position & flowing direction reference to list.
2. The position of self-priming unit is right side of the maintenance hole.

ITEMS			
BORE	DISCHARGE	mm	250
BORE	SUCTION	mm	250
	DISCHARGE PRESSURE(G)	MPa	0.20
	SUCTION HEAD	MPa	-0.05
	TOTAL HEAD	MPa	0.25
	CAPACITY	m ³ /h	300
	PUMPING LIQUID	S.W.	
MOTOR	OUTPUT	kW	30
	VOLTAGE	V	440
	FREQUENCY	Hz	60
	NO. OF REVOLUTION	r/min	1800
	HYDRAULIC TEST(G)	MPa	0.50

GUAGE PIPE IS COPPER

FITTING(1PUMP)		
NAME OF PART	Q'TY	
PRESS. GAUGE(0~0.4MPa)	1	
COMP. GAUGE(0.4MPa~-0.1MPa)	1	
GAUGE JOINT	2	
GAUGE ROOT VALVE	2	
GAUGE BOARD	1	
COUPLING	1	
COMPANION FLANGE	EACH 1	
PRIMING UNIT	1	

EMCE-250MCT BC C3326H21001

MASS	PUMP	290kg	MOTOR	254kg		DIMENSION:mm	⊕
SERVICE	NO.1 MAIN COOL. S. W. PUMP					Q'TY	1SHIP 1 SET
MODEL	EMCE-250MCT						
DRAWING NO.	H0E56A2C2539						

TAIKO KIKAI INDUSTRIES CO.,LTD.